

Advanced Networking

**Voice over IP
&
Other Multimedia Protocols**

Renato Lo Cigno
Renato.LoCigno@dit.unitn.it

SIP: Session Initiation Protocol

- Defined by IETF
- RFC 2543 (first release march 1999)
 - many other RFCs ... see IETF site and later on
- Multiparty MULTimedia Session Control (Mmusic) WG
- Born from Mbone experience and as a more "Internet" alternative to H.323

 Renato.LoCigno@dit.unitn.it Advanced Networking – VoIP - 2 2

IETF service vision

- **First objective is connectivity**
 - Transport through IP
 - Intelligence is in hosts and not in network nodes (routers) which only switch and forward datagrams
- Scalability and Security are primary concerns ... although scalability is addressed, while security ...
- SIP is an umbrella protocol suite using other light mono-function protocols
 - Avoid function duplication
 - Modular development

 Renato.LoCigno@dit.unitn.it Advanced Networking – VoIP - 2 3

SIP: general characteristics

- Client - server protocol
- The usage is: "invite" users in participation to multimedia sessions
- Uses several http-derived functionalities
- Independent from the transport layer
- Should be Scalable, Modular and Simple
- Defining a suite is based on the use of other protocols
 - RTP/RTCP (voice/video conversational transport)
 - SDP: Session Description Protocol
 - SAP: Session Announcement Protocol
 - RTSP: Real Time Streaming Protocol (VoD like)



SIP: A General Purpose Session Control Protocol?

- SIP is not limited to IP telephony
 - SDP quite flexible
 - arbitrary payloads allowed
- Other applications relying on notion of session:
 - distributed virtual reality systems
 - network games
 - video conferencing
- Applications may leverage SIP infrastructure (Call Processing, User Location, Auth., etc.)
 - Instant Messaging and Presence
 - SIP for Appliances !?!?!?



SIP: it's not...

- A transport Protocol
- A QoS Reservation Protocol
- A gateway Control Protocol
- It does NOT dictate ...
 - product features and services (color of your phone and distinctive ringing melodies, number of simultaneous calls your phone can handle, don't disturb feature, ...)
 - network configuration



SIP: Architectural Elements

- Client (o end system)
 - Send SIP requests
 - Normally embedded into a SIP User Agent Server
- User Agent Server (UAS)
 - Answers incoming queries and calls
- Redirect Server
 - Redirect calls to another server
- Proxy Server
 - Send Requests to another server, including UASs



SIP: Addresses and Methods

- Addresses are URI (Universal Resource Identifier):
 - sip:jdrosen@bell-labs.com:5067
 - sip:ann:passwd@lucent.com
- 6 methods (or primitives):
 - INVITE: Starts or invite to a conerence
 - BYE: Closes a participation
 - CANCEL: Terminates a search (unsuccessful)
 - OPTIONS: Query a client on his "capabilities"
 - ACK: Accept a call (IVITE)
 - REGISTER: Registers a client onto a server, normally a proxy, include location information



SIP: Message syntax

- Derived from HTTP:
INVITE gerla@cs.ucla.edu SIP/2.0
From: locigno@dit.unitn.it (Renato Lo Cigno)
Subject: Next visit to L.A.
To: gerla@cs.ucla.edu (Mario Gerla)
Call-ID: 1999284605.56.86@
Content-type: application/sdp
CSeq: 4711
Content-Length: 187

- Make use of the Session Description Protocol (SDP)



Session Description Protocol

- Textual syntax for multimedia sessions (unicast and multicast)
- Basic characteristics
 - Describes Audio/Video flows that from the session and the related parameters
 - Includes addresses (internal ports) for the termination of different streams
 - "Commands" initial and termination times



SDP: an example

```
v=0 Protocol version
o=loCigno 28908044538 289080890 IN IP4 93.175.132.118
  <creator> <session id> <version> <network type> <address>
s=SIP Tutorial Session name
e=ghittino@csp.it Email address
c=IN IP4 126.16.69.4 Connection information
t=28908044900 28908045000 Time the session is active (start – stop)
m=audio 49170 RTP/AVP 0 98 Media name and transport address
a=rtpmap:98 L16/11025/2 Media attribute line
```



Session Announcement Protocol

- Announces multimedia sessions via multicast
- Uses SDP for the description and RTP for media distribution
- Can be used for VoIP conferencing, but it is rarely done

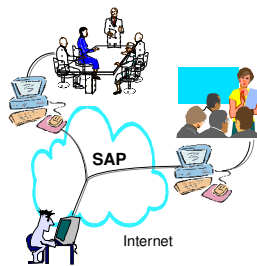

Real Time Streaming Protocol

- "Media server" control for "on-demand" services
- VCR-like controls:
 - Play, Pause, Fast-forward, Rewind, Record, ...
- An RTSP server can be queried by a client using standard SIP invitation
- The session is again described through SDP

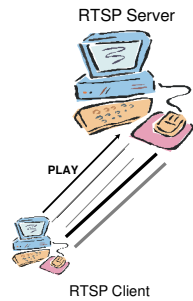

Renato.LoCigno@dit.unitn.it

Advanced Networking – VoIP - 2 13

SIP: Voice Call example

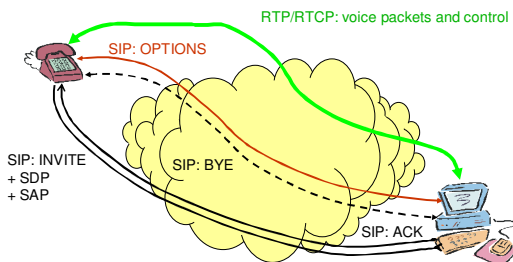

Renato.LoCigno@dit.unitn.it

Advanced Networking – VoIP - 2 14

SIP Servers and Clients

- User Agent (user application)
 - UA Client (originates calls)
 - UA Server (listens for incoming calls)
 - both SW and HW available
- SIP Proxy Server
 - relays call signaling, i.e. acts as both client and server
- SIP Redirect Server
 - redirects callers to other servers
- SIP Registrar
 - accept registration requests from users
 - maintains user's whereabouts at a Location Server (like GSM HLR)



Renato.LoCigno@dit.unitn.it

Advanced Networking – VoIP - 2 15

Proxy Server Functionality

- Serve as rendezvous point at which callees are globally reachable
- Perform routing function, i.e., determine to which UA/proxy/redirect an incoming call should be relayed
- **Allow the routing function to be programmable**
- **Forking: Several destinations may be tried for a request sequentially or in parallel**
- May serve as AAA trigger points



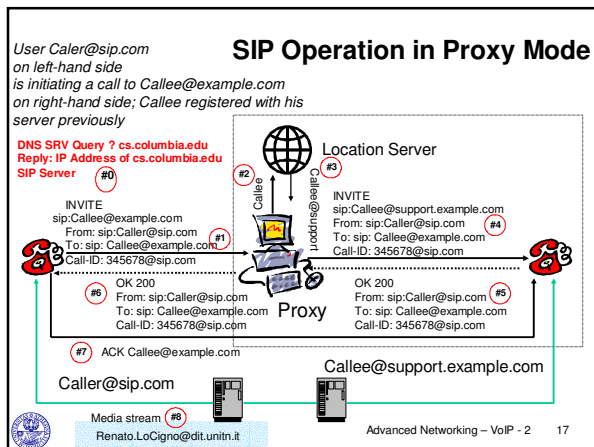

SIP RFC2543 Methods

- **INVITE**: initiates sessions
 - Request URI indicated destination; may be changed on the path
 - session description included in message body
 - re-INVITEs used to change session state
- **ACK**: confirms session establishment
 - can only be used with INVITE
- **BYE**: terminates sessions
- **CANCEL**: cancels a pending INVITE
 - if a CANCEL follows a RE-INVITE the session is not torn down!
- **OPTIONS**: capability inquiry
 - replied as INVITE
 - may include Allow, Accept, Accept-Encoding, Accept-Language, Supported,...
- **REGISTER**:



SIP REGISTER Method

- REGISTER binds a permanent address to current location
- similar to registering with HLRs in GSM
- REGISTERS may be multicast
- may convey user data (e.g., CPL scripts)
- default registration timeout: 3600 s
- may be also used to cancel or query existing registrations



SIP Extension Methods

- INFO mid-call signaling
(RFC 2976)
- COMET precondition met
(draft-ietf-sip-manyfolks-resource)
- PRACK provisional reliable responses
acknowledgement (draft-ietf-sip-100rel)
- SUBSCRIBE/ NOTIFY/ MESSAGE instant messaging
(draft-rosenberg-imp-*)



SIP Response Codes

- Borrowed from HTTP: **xyz** explanatory text
- Receivers need to understand **x**
- **x80** and higher codes avoid conflicts with future HTTP response codes
- **1yz** Informational
 - 100 Trying
 - 180 Ringing (processed locally)
 - 181 Call is Being Forwarded
- **2yz** Success
 - 200 ok
- **3yz** Redirection
 - 300 Multiple Choices
 - 301 Moved Permanently
 - 302 Moved Temporarily
- **4yz** Client error
 - 400 Bad Request
 - 401 Unauthorized
 - 404 Not Found
 - 405 Method not Allowed
 - 407 Proxy Authentication Required
 - 415 Unsupported Media Type
 - 482 Loop Detected
 - 486 Busy Here
- **5yz** Server failure
 - 500 Server Internal Error
- **6yz** Global Failure
 - 600 Busy Everywhere



SIP Message Structure

Request Method	Response Status
INVITE sip:UserB@here.com SIP/2.0 Via: SIP/2.0/UDP here.com:5060 From: BigGuy <sip:UserA@here.com> To: LittleGuy <sip:UserB@here.com> Call-ID: 12345600@here.com CSeq: 1 INVITE Subject: Happy Christmas Contact: BigGuy <sip:UserA@here.com> Content-Type: application/sdp Content-Length: 147 Message Header Fields	SIP/2.0 200 OK Via: SIP/2.0/UDP here.com:5060 From: BigGuy <sip:UserA@here.com> To: LittleGuy <sip:UserB@here.com>,tag=65a35 Call-ID: 12345601@here.com CSeq: 1 INVITE Subject: Happy Christmas Contact: LittleGuy <sip:UserB@here.com> Content-Type: application/sdp Content-Length: 134
v=0 o=UserA 2890844526 2890844526 IN IP4 here.com s=Session SDP c=IN IP4 100.101.102.103 t=0 0 m=audio 49172 RTP/AVP 0 a=rtpmap:0 PCMU/8000 Download <div style="background-color: yellow; padding: 2px;"> "receive RTP G.711-encoded audio at 100.101.102.103:49172" </div>	v=0 o=UserB 2890844527 2890844527 IN IP4 here.com s=Session SDP c=IN IP4 110.111.112.113 t=0 0 m=audio 3456 RTP/AVP 0

Renato.LoCigno@dit.unitn.it Advanced Networking – VoIP - 2 22

SIP Addresses

- URLs used to identify a call party a human being or an automated service
- examples:
 - sip:voicemail@example.com?subject=callme
 - sip:sales@bigcom.com; geo.position:=48.54_-123.84_120
- must include host, may include user name, port number, parameters (e.g., transport), etc.
- may be embedded in Webpages, email signatures, printed on your business card, etc.
- address space unlimited
- non-SIP URLs can be used as well (mailto:, http:, ...)

Renato.LoCigno@dit.unitn.it Advanced Networking – VoIP - 2 23

SIP Server -- Proxy versus Redirection

- A SIP server may either **proxy** or **redirect** a request
 - statically configured
 - dynamically determined (CPL).
- Redirection
 - a user moves or changes her provider (PSTN: "The number you have dialed is not available.")
 - caller does not need to try the original server next time. Stateless.
- Proxy useful if
 - forking, AAA, firewall control needed
 - proxying grants more control to the server

Renato.LoCigno@dit.unitn.it Advanced Networking – VoIP - 2 24

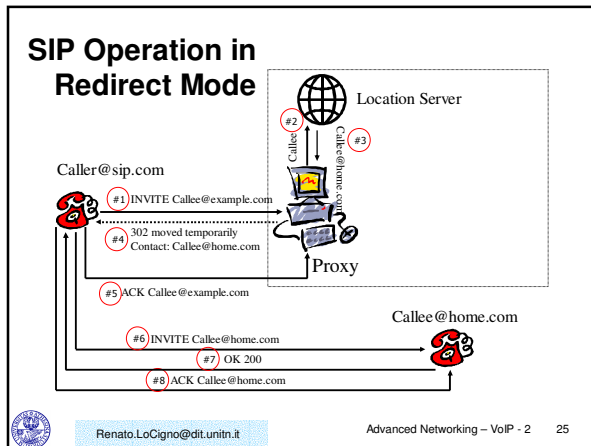

- **Mobility**
 - User mobility
 - Service mobility
 - 3GPP
- Renato.LoCigno@dit.unitn.it Advanced Networking – VoIP - 2 26

- ### SIP and Terminal Mobility
- Terminal can move between subnetworks
 - Issues to consider:
 - Handoff performance
 - Redirection authentication
 - Mobile hosts (MH) inform their home proxy about their new locations using REGISTER
 - Mid-call mobility (Session mobility) is dealt with using reINVITE
- Renato.LoCigno@dit.unitn.it Advanced Networking – VoIP - 2 27

SIP and Terminal Mobility

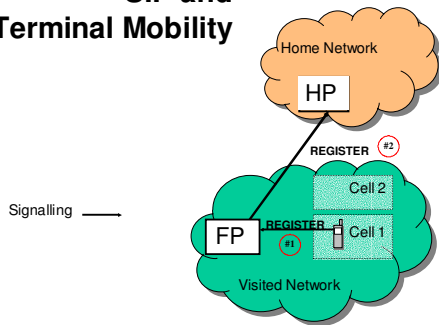

SIP and Terminal Mobility

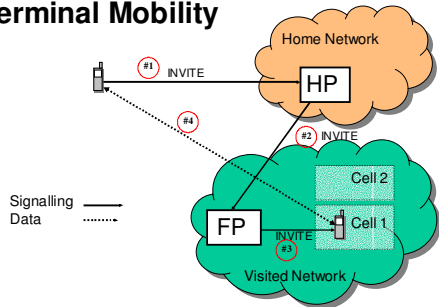

SIP and Terminal Mobility

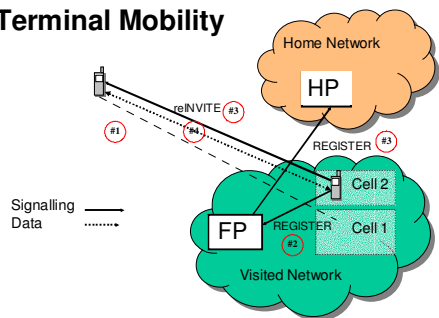

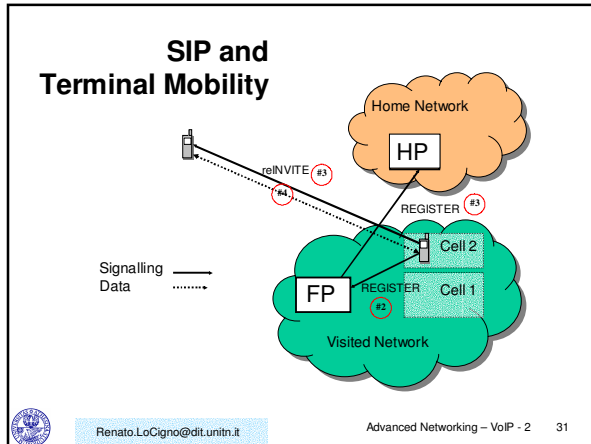

- ### SIP and Personal Mobility
- Person uses different devices
 - REGISTER binds a person to a device
 - Proxy and redirect translate address to location and device
 - Issues to consider:
 - Authentication
 - Binding different addresses to single person: LDAP ...
- Renato.LoCigno@dit.unitn.it Advanced Networking – VoIP - 2 32

- ### SIP and Service Mobility
- Use same services from different locations and devices
 - speed dial, address book, media preferences, call handling
 - Services located at home server
 - RECORD-ROUTE home proxy to force calls to be processed by home servers
 - Services located at end systems
 - retrieve with REGISTER
 - Issues to consider
 - services need to be device independent
 - standardised service description (CPL)
 - User recognition and authentication
- Renato.LoCigno@dit.unitn.it Advanced Networking – VoIP - 2 33

SIP & 3GPP

- Può rappresentare una delle "alleanze" più promettenti per l'integrazione delle TLC (soprattutto fisso/mobile)
- Punta all'integrazione della mobilità con i servizi streaming in IP
- Introduce espressamente in 3G SIP ed un nodo di controllo della multimedialità su IP: CSCF (Call/Session Control Function)